

RS-232 TO RS-422/RS-485 Isolation Interface Converter ATC-105 User's Manual

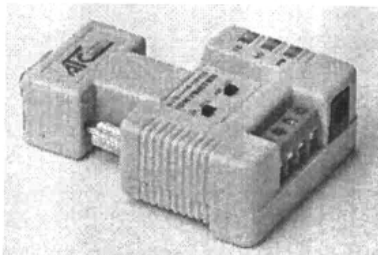

1.0 General introduction:

ATC-105 Isolation Interface Converter is compatible with RS-232C, RS-422, RS-485 standards and capable of converting single end RS-232 signal into RS-422 or RS-485 signal of balanced signal. The built in photoelectric isolator can offer 3500V isolation voltage and the rapid Transient Voltage Suppressor (TVS) can effectively inhibit lightning and ESD, prevent lightning strike and common code interference. Connect PC, IPC, or portable computer via a DB9 female connector at RS-232 interface, and connect RS-422, RS-485 end via convenient 4-bit terminal. The RS-485 supports dual-line half duplex, namely, the only two lines of RS-485 shall both send and receive data. Handshake signal (e.g. RTS, Request To Send) usually controls the data direction. The inner circuit of ATC-105 Photoelectric Isolation Interface Converter can detect data direction and switch to control it automatically, conveniently to form a RS-485 network without any shake hand signal. This kind of RS-485 control is fully transparent and need no software amendment for the former working modes basing on RS-232.

ATC-105 Photoelectric Isolation Interface Converter can provide credible connection for point to point, point to multi-point communication. The point to multi-point allows connecting 32 RS-422 or RS-485 interface devices with data transmission speed of 0-115.2KBPS. The dual color data flow indication light can indicate malfunction. It supports communication modes including RS-232C to RS-422, RS-232 to RS-485 conversion.

2.0 Performance parameter

- 2.1 Interface feature: interface is compatible with EIA/TIA RS-232C, RS-485/RS-422 standard
- 2.2 Electric interface: RS-232C interface DB9 Female connector RS-422/RS-485 interface 4-bit terminal
- 2.3 Transmission media: twisted-pair cable or shielded cable
- 2.4 operation mode: asynchronous half or full duplex
- 2.5 Signal indication: 3 signal indication lights indicate TD, RD and PWR
- 2.6 Isolation: isolation voltage 3500VRMS 500VDC sequence
- 2.7 Transmission speed: 115.2K BPS to 300M
38.4K BPS to 2.4KM
9600 BPS to 5KM
- 2.8 Protecting grade: RS-232 interface+15KV ESD protection, RS-422, RS-485 interface 600W lightning strike and surge protection on each line
- 2.9 Transmission distance: 0-5 kilometers (115200-9600BPS)
- 2.10 Size: 85mmx54mmx25mm
- 2.11 Working environment: -25°C to 70°C, 5% to 95% relative humidity

3.0 Connector and signal

RS-232 DB9 Female Connector Pinout

DB9 Female	RS-232
PIN2	TXD
PIN3	RXD
PIN5	GND

RS-422/485 Terminal Pinout:

Terminal No	1	2	3	4
RS-422	T+	T-	R-	R+
RS-485	485+	485-	-	-

4.0 Installation setup and application:

Please read the User's Manual carefully before installing ATC-105 Photoelectric Isolation Interface Converter. Insert the power converter of the product into +9V socket, connect RS-422 or RS-485 device at one end according to the pin definition instruction of 4-bit terminal. ATC-105 product has 2 toggle

switches. The left one is a select switch for DTE, DCE of RS-232 interface. Note: switch to DCE position if connect PC serial port (DTE interface definition); switch to DTE position if connect other RS-232 devices (DCE interface definition). The right is the select switch for RS-422/RS-485 conversion mode and the user may select according to own needs.

ATC-105 interface converter supports following communication modes:

1. point to point/4 wire full duplex
2. point to multi-point/4 wire full duplex (Four wire RS-485)
3. point to point/dual-line half duplex
4. point to multi-point/ dual-line half duplex

RS-232 to RS-422 conversion: set ATC-105 interface converter switch to RS-422 position.

RS-232 to RS-485 conversion: set ATC-105 interface converter switch to RS-485 position.

5.0 Sketch map for communication connection

RS-232 to RS-422 conversion

5.1 RS-422 point to point/4 wire full duplex communication

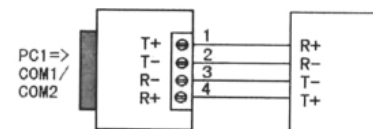

5.2 RS-422 point to multi-point/4 wire full duplex RS-485

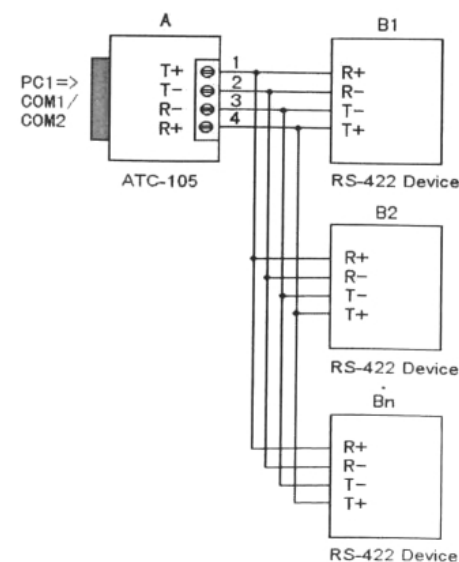

5.3. Full duplex communication connection between ATC-105 interface converters

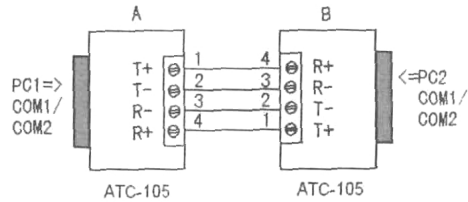

RS-232 to RS-485 conversion

5.4 RS-485 point to point/ dual-line half duplex

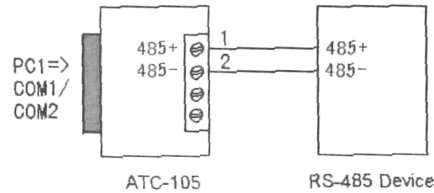

5.5 RS-485 point to multi- point /dual-line half duplex

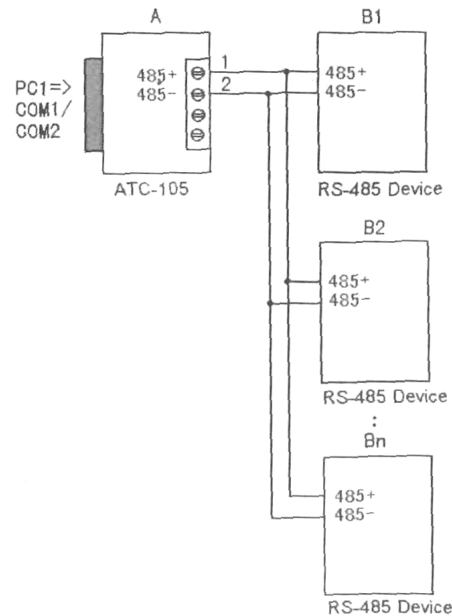

5.6 Half duplex communication connection between ATC-105 interface converters

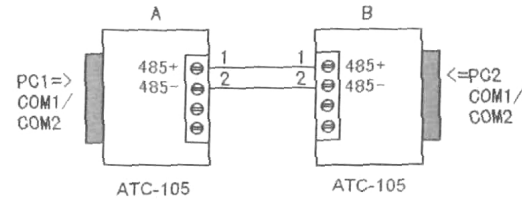

6.0 Trouble shooting

6.1 Data transmission failure:

- check to make sure the RS-232 interface is correctly connected
- check to make sure the RS-422 interface is correctly connected
- check to make sure the RS-485 interface is correctly connected
- check to make sure the power supply is normal
- check to make sure the switch setup is in the correct conversion mode
- check to make sure the DTE, DCE switch is in the correct interface setup mode. **Note: switch to DCE position if connect PC serial port (DTE interface definition) ; switch to DTE position if connect other RS-232 devices (DCE interface definition) . When the toggle switch on the left of ATC-105 interface converter is on DCE position, the inner definition of DB9 female RS-232 interface is: PIN2 is TXD, PIN3 is RXD. When the toggle switch on its left is on DTE position, the inner definition of DB9 female RS-232 interface is: PIN2 is RXD, PIN3 is TXD.**

6.2 Data loss or error:

- Check the consistency of the data speeds and formats at the both ends of the data communication device.